

INTERCOMPACT Series

Compact Signal & Ethernet PCB connectors

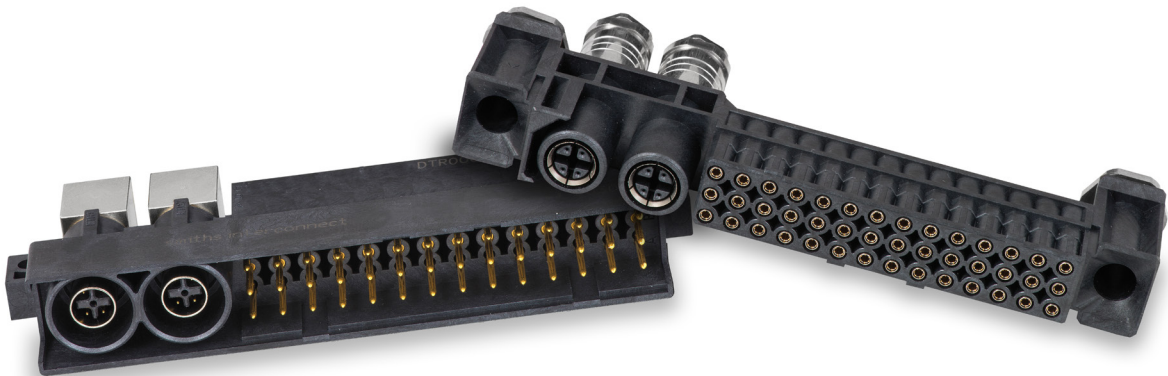

Available Contact Technologies *(Features & Benefits)*

Hypertac[®] Hyperboloid contact

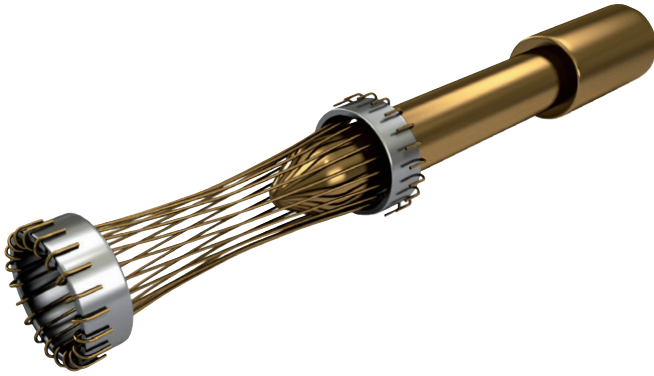

- **Long Contact Life**

Industry-leading mating cycles (over 100,000) provide low cost of ownership

- **Low Insertion / Extraction Forces**

Ergonomic mating without mate assist hardware for cost and space saving

- **Lower Contact Resistance**

Low power consumption / lower voltage drop across connector

- **Higher Current Ratings**

Smaller contacts needed to carry power reduce size and weight

- **Immunity to Shock & Vibration**

Reliability under harsh environmental conditions

- **360° Contact Wipe**

Self-cleaning contacts assure uninterrupted connection

- **Restricted materials**

RoHS compliant with Exemption 6c

Quadrax contact

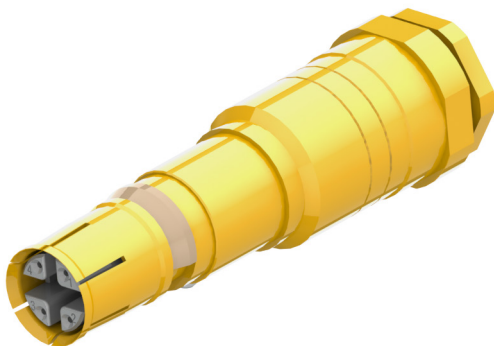

- **Contact layout**

Consist of an outer shield with four inner paired conductors forming two 100 Ohm, controlled impedance differential pairs

- **High speed**

Designed for transmission of Ethernet high speed signal up to 100 MHz in harsh environments where integrity and reliability are essential

- **Ethernet standard**

Ethernet 10-Base-T / 100-Base-Tx - Category 5E

- **Cable features**

Cable cross section 4 x 0,25 mm² (AWG24), performance of 100 Ohm between 1 to 100MHz.

- **Restricted materials**

RoHS compliant with Exemption 6c

INTERCOMPACT Series



The Intercompact Series is Smiths Interconnect's answer to the rail and industrial market growing demand for compact, high-speed, and reliable connectivity for ECU boxes, in the respect of severe material and electric current requirements.

The new generation of Electronic Control Unit boxes requires a sophisticated interconnect solution able to support steadily all I/O signals that the advanced devices handle.

The Intercompact Series is an innovative solution for PCB to PCB and floating mounting rack and panel applications currently offered in both signal and Ethernet versions. Designed to meet the requirements of the rail and industrial environments, it is also suitable for other demanding markets such as defence, space and test & measurement.

Optimized and qualified for the next generation of Electronic Control Units

Features & Benefits

- 60 and 41 way signal configurations with Hypertac® Hyperboloid contacts.
- 42 ways signal and 1 or 2 high speed quadax 100 Ohm contacts as Ethernet versions. Additional contact positions can be offered depending on the specific application requirements.
- Compliance with the main European Railway standards (EN45545-2, NF F61030, EN50155:2017, STM-S-001ind.D and more).
- Compliance with MIL-C-28748 and MIL-STD-202-301 standards and EIA and IEC standards for Contact Resistance and Environmental testing.
- Insulators in Liquid Cristal Polymer material for an optimized insulation resistance in severe environmental conditions.

Technical Characteristics

	Signal configurations	Ethernet configurations	Standards
Contact Arrangements	Up to 60	Up to 42 hyperboloid contacts Up to 2 quadrax contacts	
Contact Diameter	Ø 1.02 mm (0,402 in)	Ø 0.35 mm (0,014 in) for quadrax internal female contact	
Contact Technology	Hypertac® Hyperboloid sockets	Quadrax contacts	

Materials & Platings

Contacts	Gold over nickel plating	
Insulator	Liquid Cristal Polymer (LCP)	

Mechanical & Environmental

Mating Cycles	> 500 cycles	NFF61-030
Temperature Range	- 55°C to 125°C	-
Vibration	Category 1 Class B + Category 2	EN 61373
Flammability	HL3 - R22	EN 45545-2
Salt Spray	> 96 hours	NFF61-030
Fluid Resistance	Gas Oil, Mineral oil, Hydrochloric Acid and Base	NFF61-030

Electrical

Current Rating	3 A per contact	0.75 A per contact	-
Nominal Voltage	110 V DC	72 V DC	EN 50124-1, OV2 PD2
Dielectric Withstanding Voltage	1500 V DC	800 V DC	EN 50124-1, OV PD2
Contact Resistance	< 4,5 mΩ	< 200 mΩ	
Insulation Resistance	>100 GΩ	>100 GΩ	

Signal configuration

60 Signal Way Plug

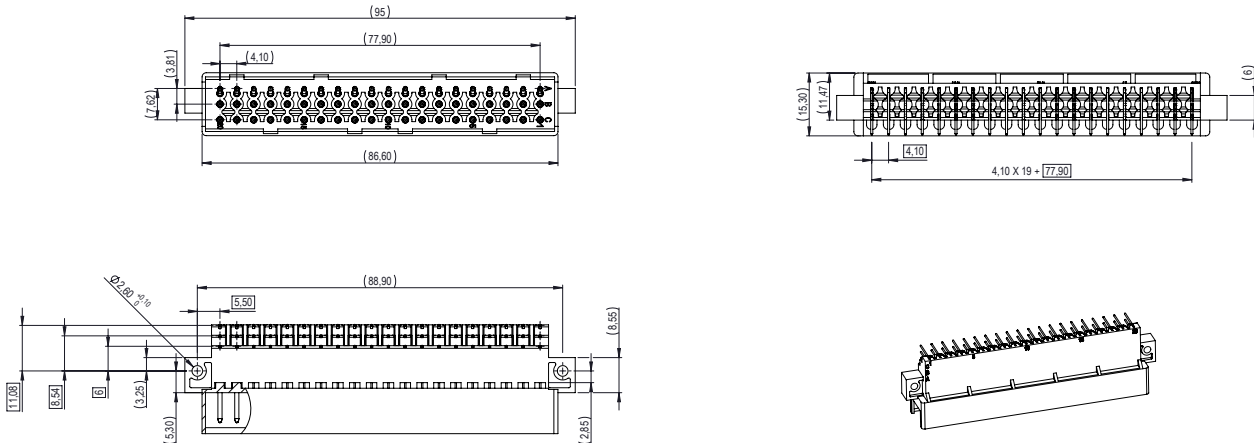

60 Signal Way Receptacle

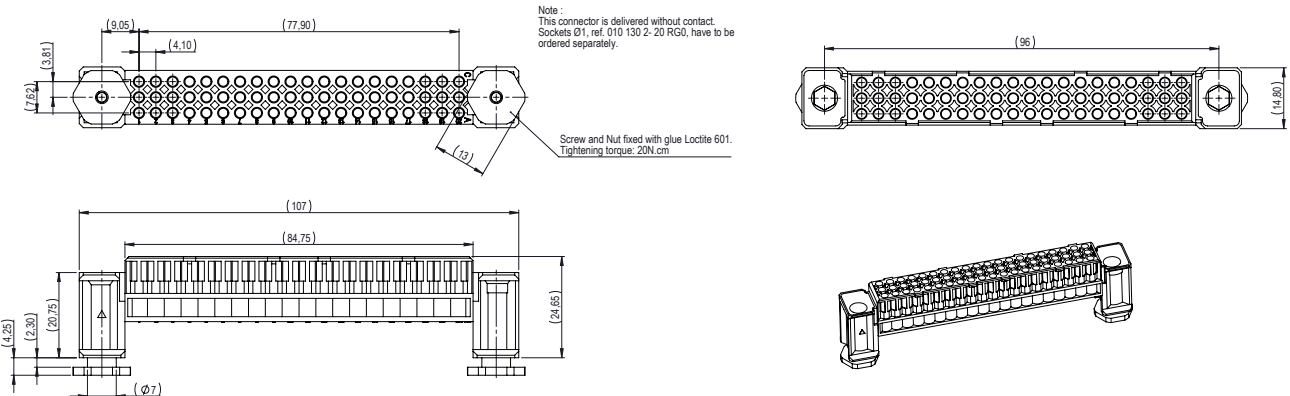

Hyperboloid socket contacts

Ref: 0101302-20RGO

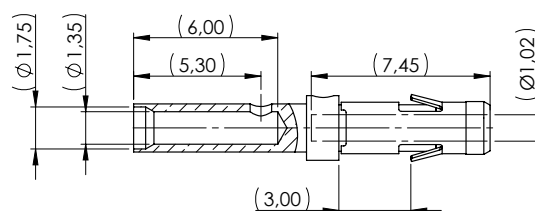

Dimensions are in mm

Signal & Ethernet configuration

42 Signal & 2 Quadraplex Way Plug

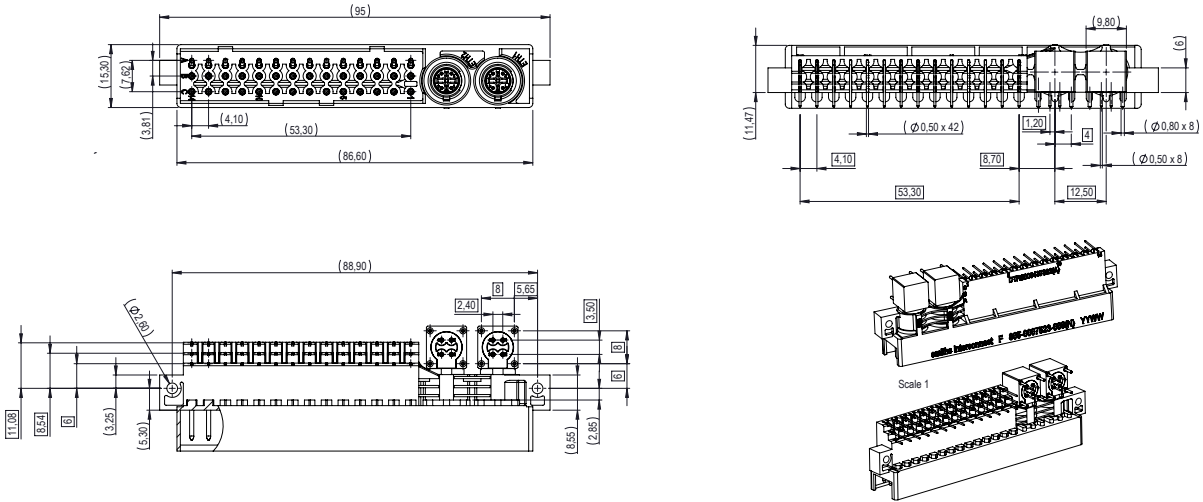

42 Signal & 2 Quadraplex Way Receptacle

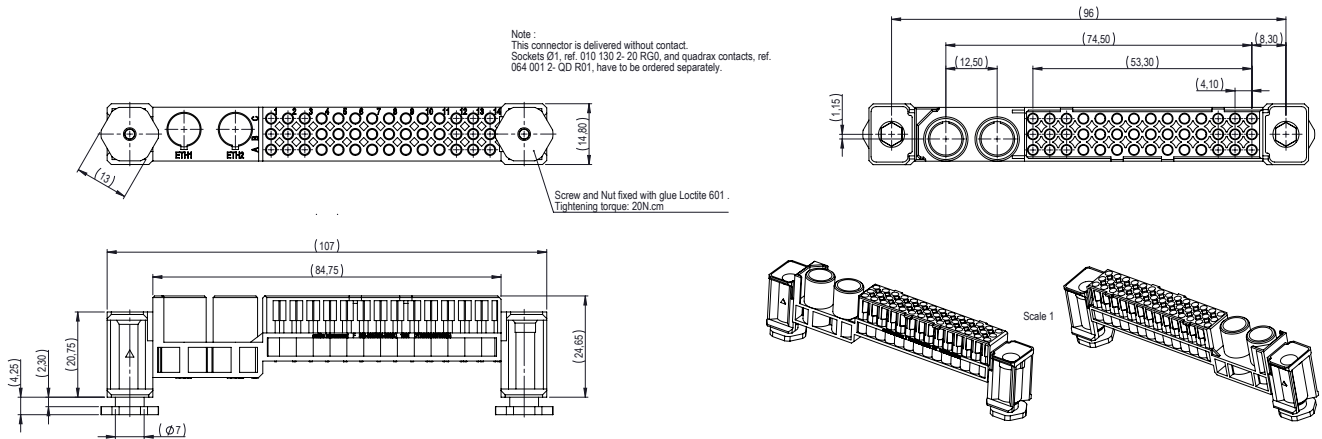

Quadraplex and Hyperboloid socket contacts

Ref: 0640012-QDR01 and 0101302-20RGO

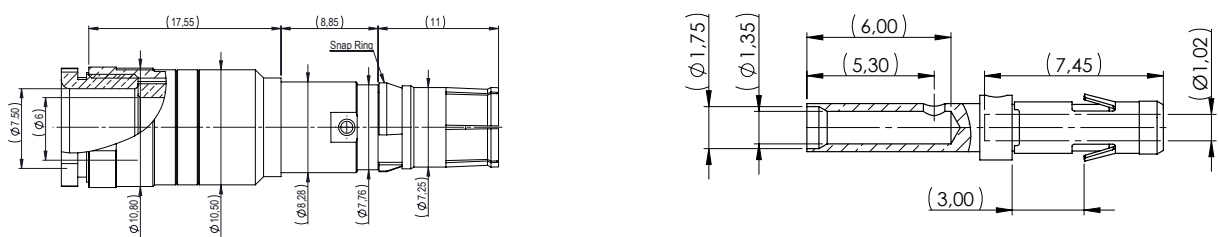

Dimensions are in mm

How to Order



1 Series	I T C Series (fixed)
2 Contact type	S - Only signal contacts S E Signal and Quadrax contacts
3 Connector type	P Plug R Receptacle
4 Contact positions**	0 0 0 - 0 0 Without contacts for S- and SE receptacles and SE plug* 0 6 0 - 0 0 Signal 60 ways (no Quadrax) 0 4 2 - 0 0 Signal 42 ways (no Quadrax) 0 4 2 - 1 1 Signal 42 ways and 2 quadrax contacts (cavity n°1 + 2) 0 4 2 - 1 0 Signal 42 ways and 1 quadrax contact (cavity n° 2) 0 4 2 - 0 1 Signal 42 ways and 1 quadrax contact (cavity n°1)
5 Termination style	0 0 Without contacts (Receptacle only) 1 0 90° PCB tail solder for sockets and pins (For receptacle and plug) 2 0 Crimp contact for sockets (Receptacle only) 3 0 Straight termination for sockets (Receptacle only)
6 Fixing system	0 0 Without fixing (Plug only) 0 1 Floating fixing (Receptacle only) 0 2 Threaded (Receptacle only)

* S- plug is sold equipped with contacts. To order the contacts separately for the other parts please refer to page 6

** For different contact configurations please contact the factory.

Crimping tool: DMC FT8, Turret TP1848



KENSINGTON

ELECTRONICS inc.

Not just products - Solutions!

INTERNATIONAL,
ALASKA & HAWAII

Please contact one
of the ISRs.

Courtney Darrah

Inside Sales Representative
cdarrah@keiconn.com
512-339-3324

Daegan Richmond

Inside Sales Representative
drichmond@keiconn.com
512-339-3331

Kevin Kientopf

Inside Sales Representative
kkientopf@keiconn.com
512-339-3315

Gabby Bozeman

Inside Sales Representative
gbozeman@keiconn.com
512-339-3325

John Davis

Inside Sales Representative
jdavis@keiconn.com
512-339-3311

North American Sales Support Coverage



Scott Kirchmeier

Regional Sales Manager
sales@keiconn.com
512-339-3312

Kevin Kientopf

Inside Sales Representative
kkientopf@keiconn.com
512-339-3315

Courtney Darrah

Inside Sales Representative
cdarrah@keiconn.com
512-339-3324

Gabby Bozeman

Inside Sales Representative
gbozeman@keiconn.com
512-339-3325

Open

Regional Sales Manager
sales@keiconn.com
512-339-3300

Open

Regional Sales Manager
sales@keiconn.com
512-339-3324

Daegan Richmond

Inside Sales Representative
drichmond@keiconn.com
512-339-3331

David Pearson

Regional Sales Manager
sales@keiconn.com
512-339-3316

Open

Regional Sales Manager
sales@keiconn.com
512-339-3300

John Davis

Inside Sales Representative
jdavis@keiconn.com
512-339-3311