

AURORA SERIES

APPLICATION GUIDE

DO NOT DISCARD, DELIVER TO MANUFACTURING.
NO DESECHE, ENTREFA A LA FEBRICACION.
INSTRUCTIONS DE MONTAGE, NE PAS JETER.
BITTE NICHT WE WERFEN, BITTE AN DIE PRODUCTION.

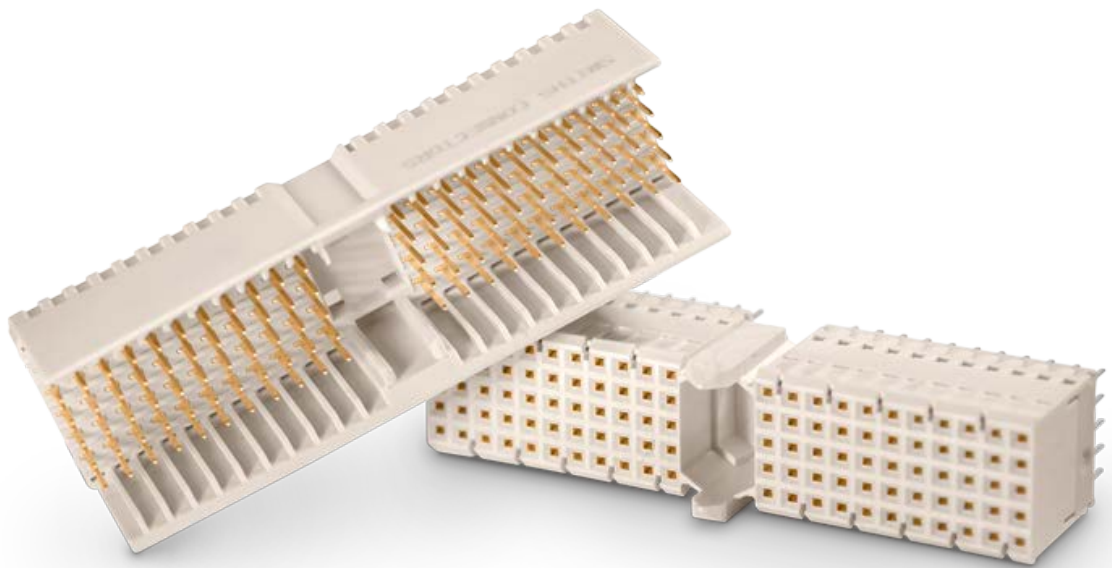

1. PRODUCT INFORMATION

P.N.	Gender	Style	Type	# of Contacts	Shielded	Peg
K3A110FS0P14301	Female	Straight	A	110	No	No
K3A110FR0P1430	Female	Right Angle	A	110	No	No
K3A110MS0P1230	Male	Straight	A	110	No	No
K3A110MS1P1230	Male	Straight	A	110	No	Yes
K3B125FS0P14301	Female	Straight	B	125	No	No
K3B125FR0P1430	Female	Right Angle	B	125	No	No
K3B125MS0P1230	Male	Straight	B	125	No	No
K3C055FS0P14301	Female	Straight	C	55	No	No
K3C055FR0P1430	Female	Right Angle	C	55	No	No
K3C055MS0P1230	Male	Straight	C	55	No	No
K3C055MS1P1230	Male	Straight	C	55	No	Yes

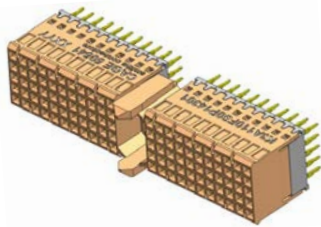

K3A110FS0P14301

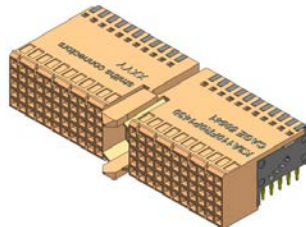

K3A110FR0P1430

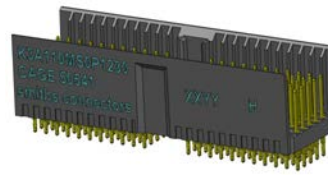

K3A110MS0P1230

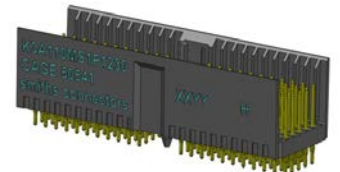

K3A110MS1P1230

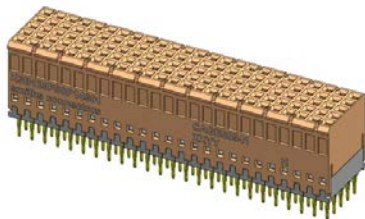

K3B125FS0P14301

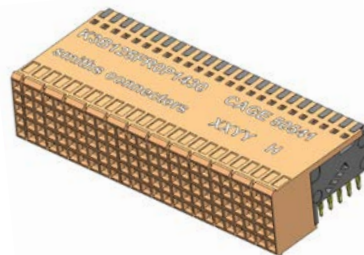

K3B125FR0P1430

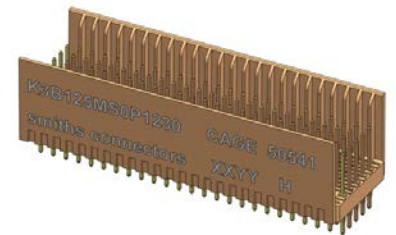

K3B125MS0P1230

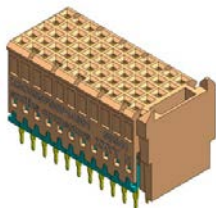

K3C055FS0P14301

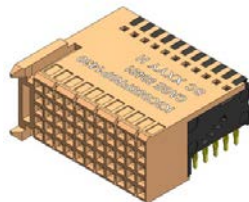

K3C055FR0P1430

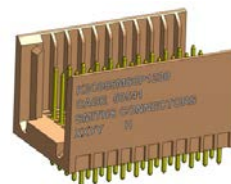

K3C055MS0P1230

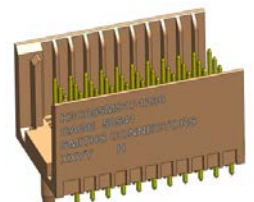

K3C055MS1P1230

2. INSTALLATION TOOLING

The Aurora 2mm connector is compatible with industry standard 2mm connector application tooling. Smiths Connectors also provides the following application tooling:

Tool PN	Compatible Aurora PNs	Description
T3160	K3A110FS0P14301	Aurora Female Straight Application Tool 110 pin
T3161	K3A110FR0P1430	Aurora Female R/A Application Tool 110 pin
T3162	K3A110MS0P1230	Aurora Male Straight Application Tool 110pin
T3163	K3B125MS0P1230	Aurora Male Straight Application Tool 125pin
T3164	K3C055FS0P14301	Aurora Female Straight Application Tool 55pin
T3165	K3C055FR0P1430	Aurora Female R/A Application Tool 55pin
T3166	K3C055MS0P1230	Aurora Male Straight Application Tool 55pin
T3167	K3B125FS0P1430	Aurora Female Straight Application Tool 125pin
T3167	K3B125FR0P1430	Aurora Female R/A Application Tool 125pin

3. INSTALLATION PROCEDURE (Caution: please wear safety glasses)

3.1 Requirements for application equipment

With the appropriate application tooling (see section 2 above) the Aurora can be assembled to the printed circuit board using manual, hydraulic or programmable presses. Prior to assembly, the following points should be followed:

- (1) The maximum force applied should not exceed the strength of the plastic. There should be no evidence of deformed or fractured plastic.
- (2) The stroke of the press should be controlled to +/-0.05mm. It is recommended that the stroke distance be adjusted with each batch to account for variation in PCB thickness.

3.2 Pressing Connector

- 3.1.1 Fit connector module to tool.

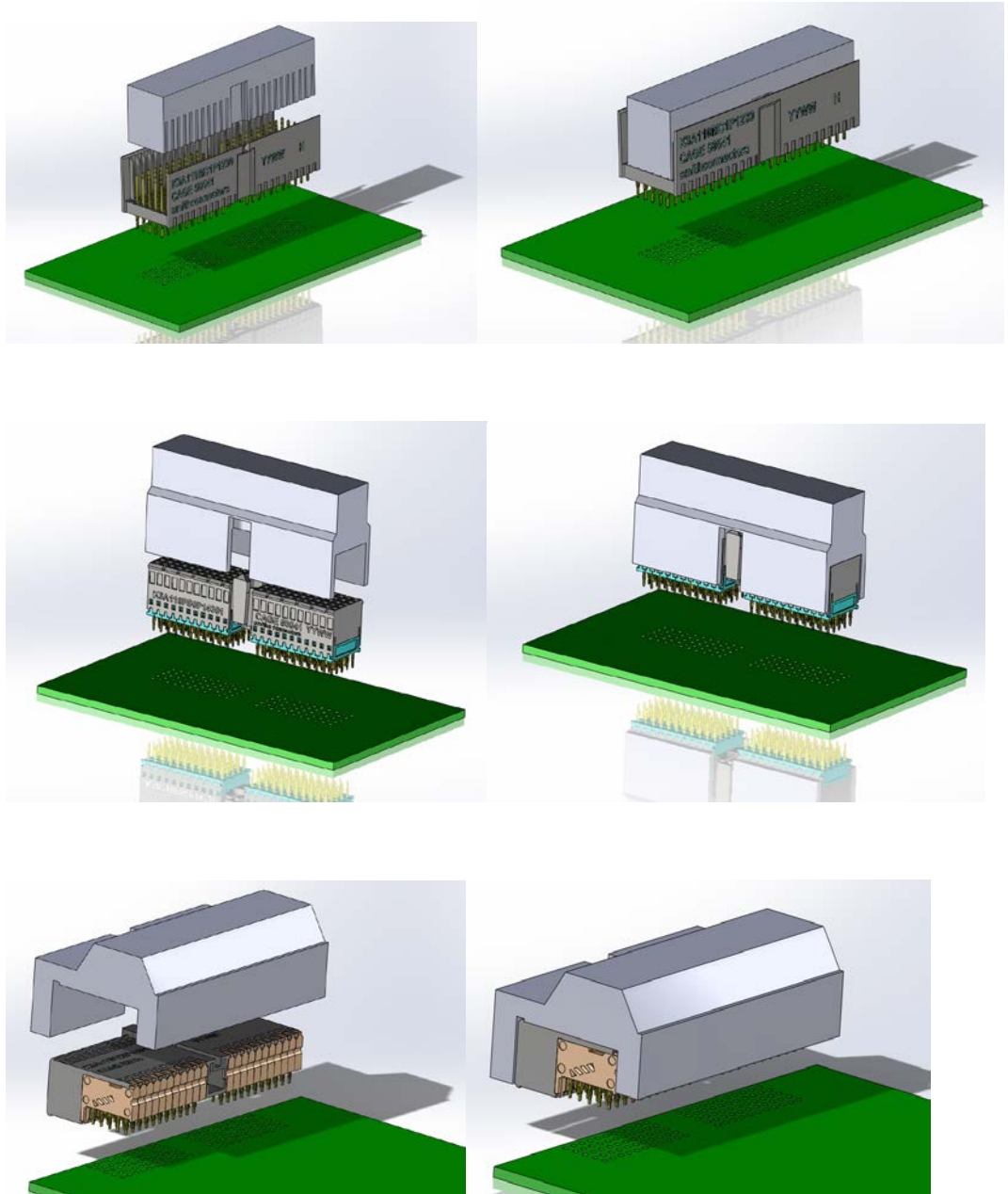

3.1.2 Align compliant terminals with printed circuit board

3.1.3 Apply steady force to center of tool. Make certain that there is no gap between the PCB and connector standoff. Approximate force per module is :

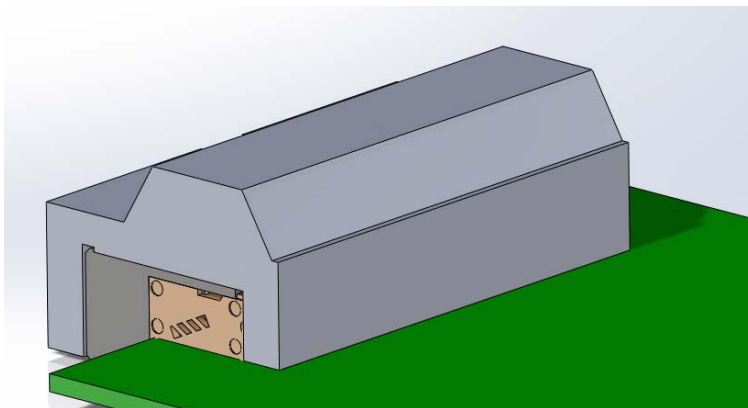
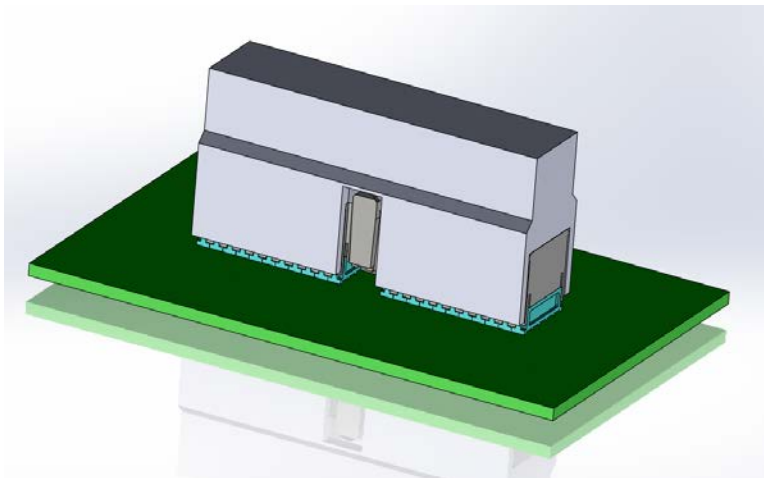
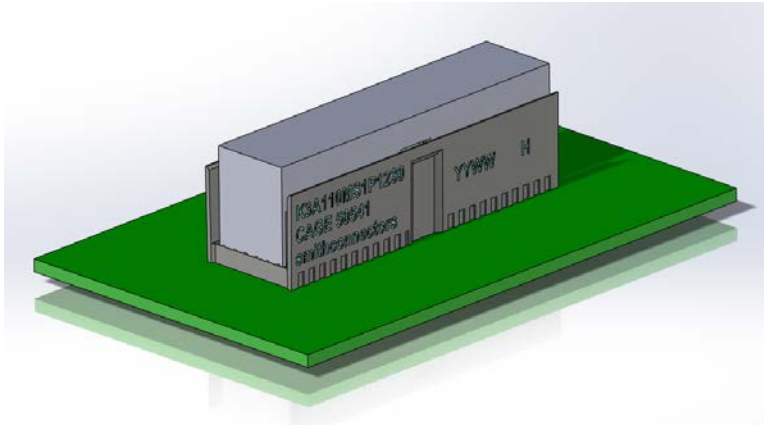

4. PRINTED CIRCUIT BOARD

PCB plated through-holed must be in accordance with specification in IEC 61076-4

4.1 Manufacturing tolerance of $\varnothing 0.6\pm 0,05\text{mm}$ finished plated-through hole:

Drilled Hole = $\varnothing 0,7\pm 0,02\text{mm}$

Cu plating = 25 μm Min.

Sn/SnPb = 15 μm Max.

4.2 PCB Mounting Pattern:

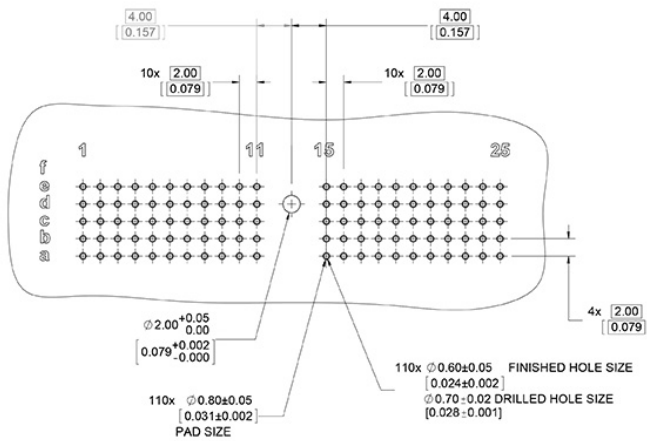

K3A110MS1P1230

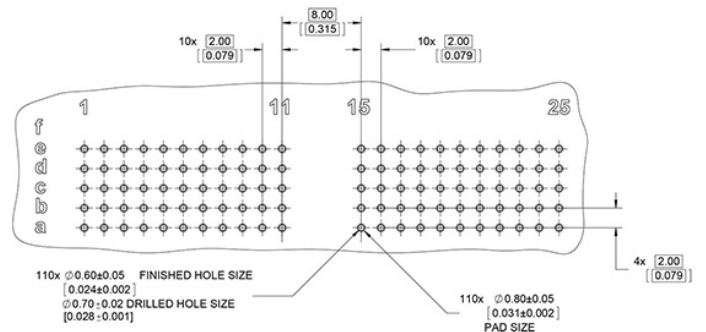

K3A110MS0P1230

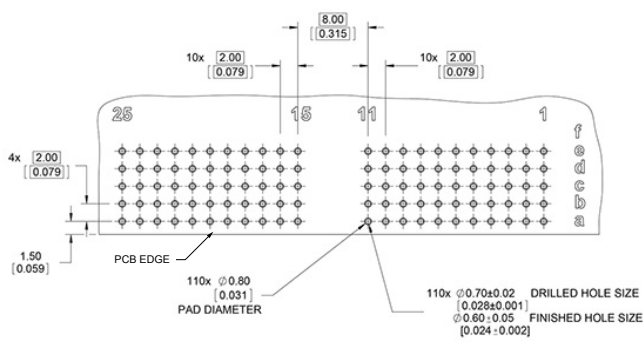

K3A110FR0P1430

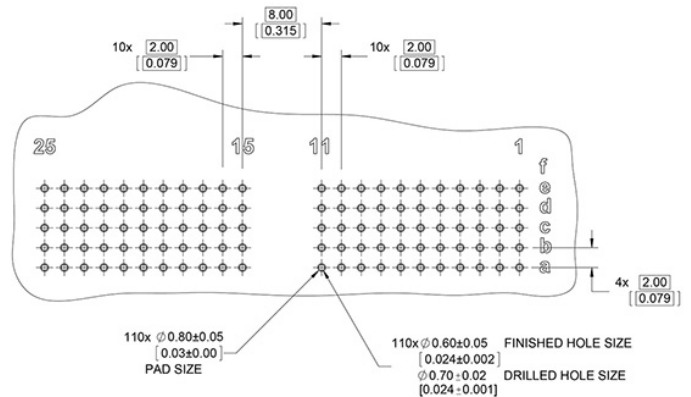

K3A110FS0P14301

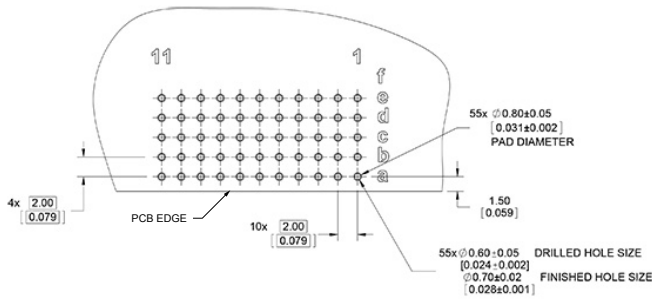

K3C055FR0P1430

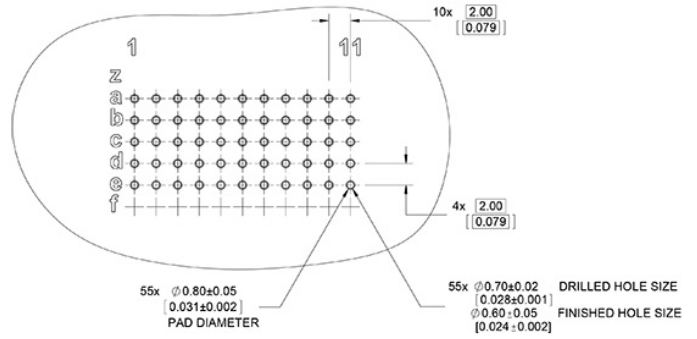

K3C055FS0P14301

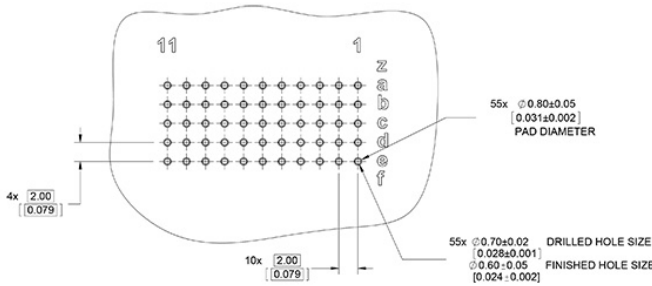

K3C055MS0P1230

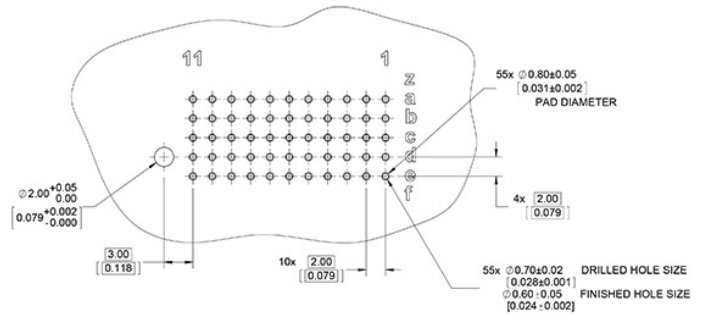

K3C055MS1P1230

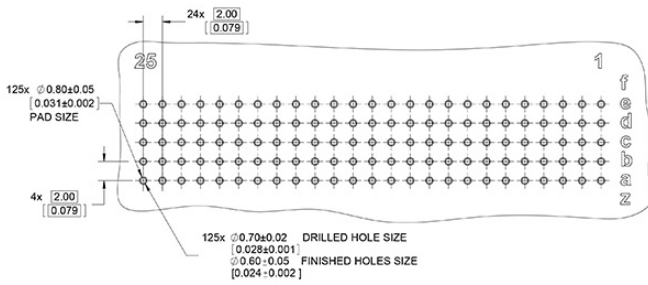

K3B125FS0P14301

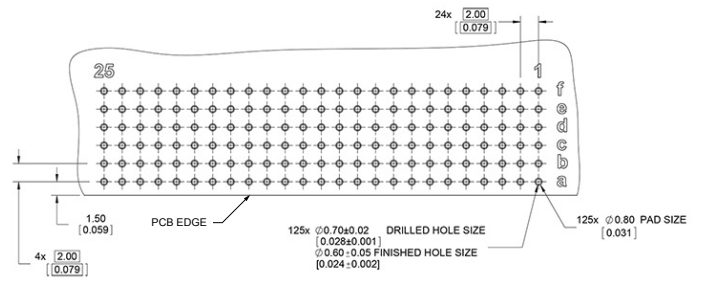

K3B125FR0P1430

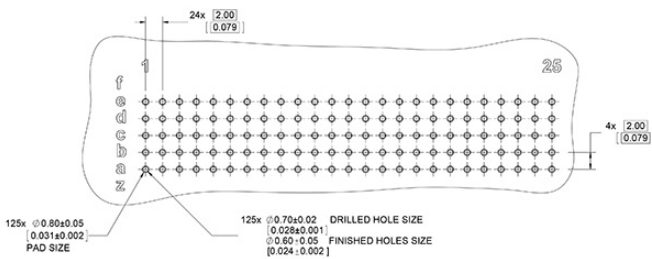

K3B125MS0P1230

SMITHS CONNECTORS

GLOBAL SUPPORT

AMERICAS

Costa Mesa, CA	1.714.371.1100
Hudson, MA	1.978.568.0451
Kansas City, KS	1.913.342.5544

EUROPE

France	33.2.32969176
Germany	49.991.250120
Italy	39.010.60361
United Kingdom	44.208.236.2400

ASIA

Shanghai, China	86.21.3318.4650
Suzhou, China	86.512.6273.1188
Singapore	65.6846.1655